

Project II

INTRODUCTION

Agenda

The Project
Concept

Project II

Module
Content

Module
Assessment

What You'll
Learn



A bit about Me

Frank Walsh



https://www.wit.ie/about_wit/contact_us/staff_directory/frank_x_walsh

Contact me via Moodle



[Github](https://github.com/fxwalsh) (<https://github.com/fxwalsh>)



[Research Gate](https://www.researchgate.net/profile/Frank_Walsh) (https://www.researchgate.net/profile/Frank_Walsh)



[LinkedIn](https://ie.linkedin.com/in/frank-walsh-a2b8867) (<https://ie.linkedin.com/in/frank-walsh-a2b8867>)

The Overall Project Concept

IoT programme aims to produce graduates who can immediately engage in industry and research

"Challenged to combine the knowledge and skills acquired in the key disciplines"

Ethos of "permissionless innovation"

- Encourage experimentation with the various technologies



Project II - Aims

You will combine skill and knowledge learned in other modules to create a project.

You will learn fundamentals of distributed version control systems.

You will learn and demonstrate basic communication skills

You will present your ideas and work.

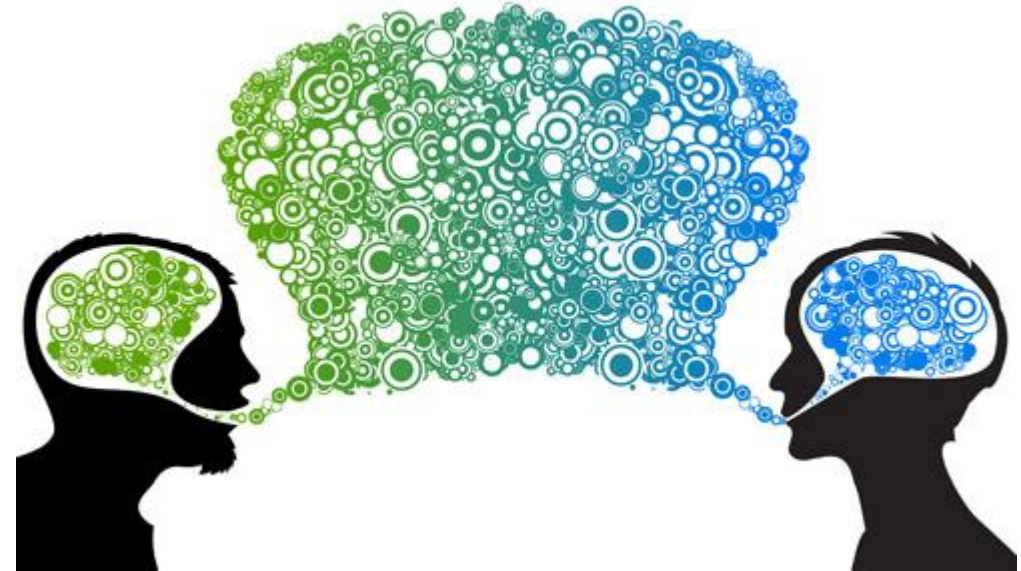

Project II Content

Come up with a an idea for a project/piece of work

Using this idea, start developing a solution

Use this to start a "digital portfolio" using a distributed version control system.

Communication of ideas and concepts in a correct, clear and modern format.

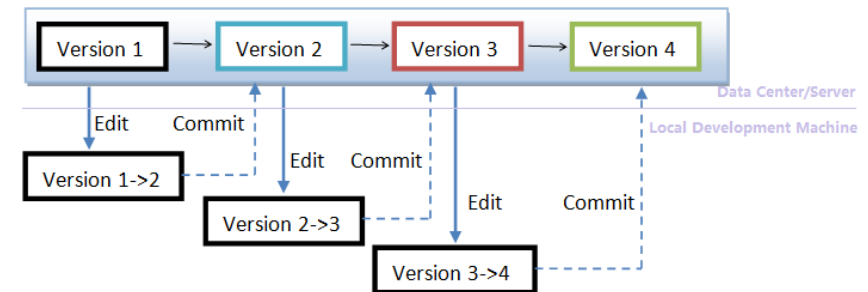

Project II - You'll learn how to

Create a working "artifact" that:

- combines core skills and knowledge from at least two domains of your programme (i.e. Programming, Computer Systems...)
- Ideally has an IoT flavour

Manage your project using a suitable version control system.

Report and communication you work through suitable documents and presentations

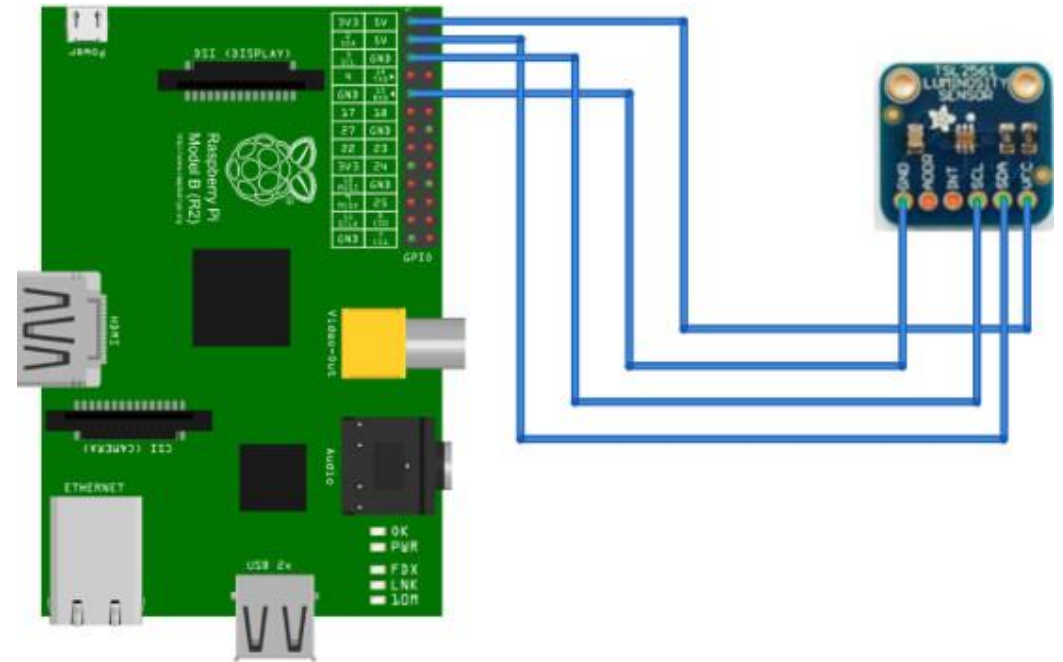

fritzing

Project II - High Level Syllabus(Tentative)

Source Control

- Git/Github/Bitbucket

Single Board Computer(SBC) Programming Basics

- Pi/ Galileo programming

Microcontroller Basics

- Arduino/Galileo

Communication Modalities and Skills

- Presentation Tools (PP/Prezzi/Trello)
- Design Tools (Fretzig)
- Documentation Tools(Markdown, Doc generation)

SBC breakout and General IO

- Bread boards, Soldering, Sensing



Domains

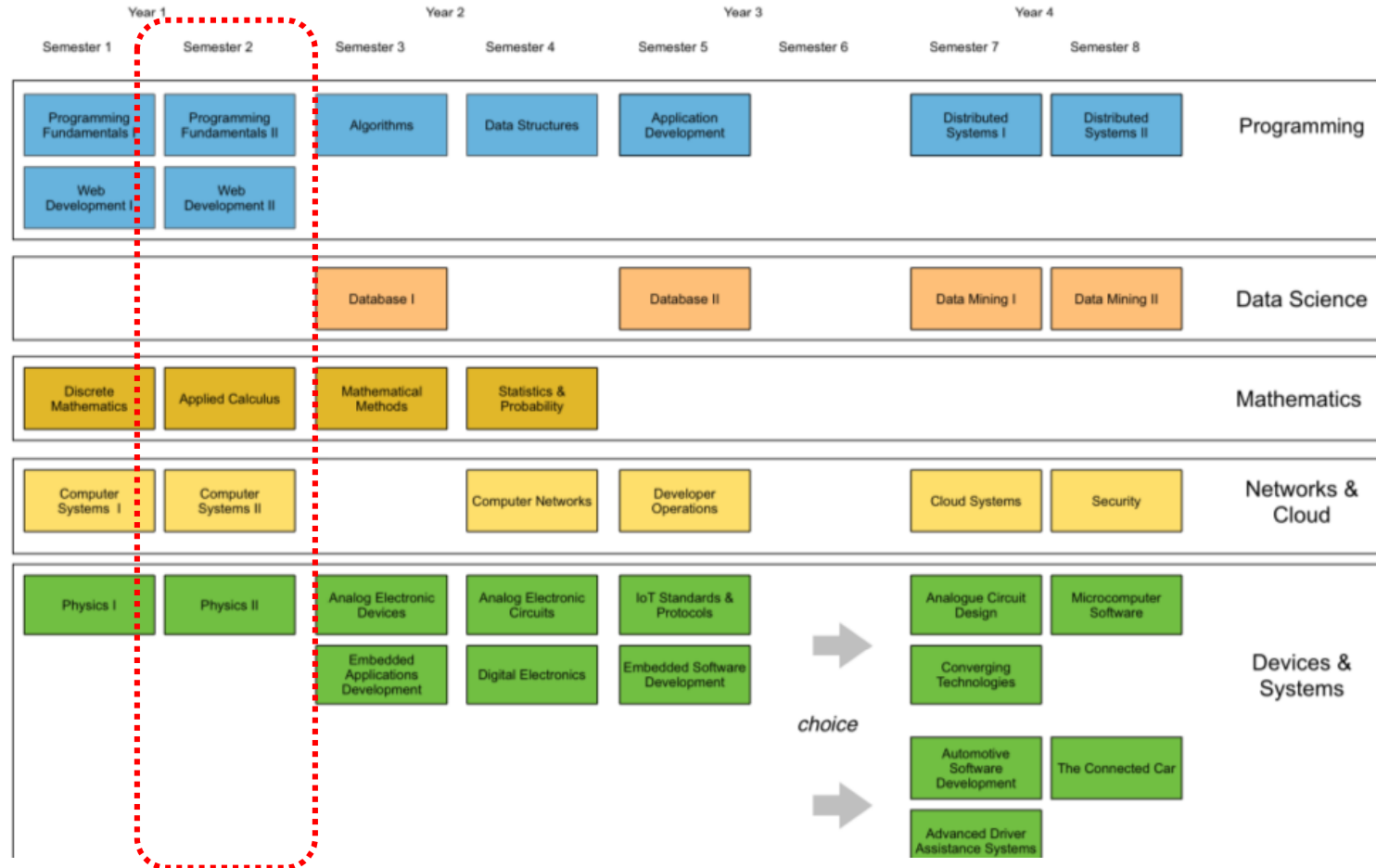

Project II - Delivery & Assessment (Tentative)

Lectures will cover supporting topics

- Version control Systems
- Project planning and design
- Technical presentation

Module is 100% Continuous Assessment

- milestones

Date	Activity
19/1/2016	1st Lecture
10/2/2016	Project Concept
17/3/2016	Status Report Presentation
27/4/2016	Project Submission
28/4/2016	Project presentation

Project II - Example

Title: Temperature Sensing Application:

Overview: Application that reads the temperature data from a digital temp sensor

Description: Writes data to a file and standard output(console). To connect the temperature sensor, the student constructs their own "breakout board" for the Single Board Computer (i.e pi) which will allow them to easily integrate various sensing and acuation circuits to the SPC via the GPIO. The application allows the user to enter a lower and upper bound for the temperature. The application displays "Too Cold" if temp is less than lower bound, "Too Hot" if temp is greater than upper bound, and "OK" otherwise.

Candidate Technologies/Domain:

Single Board Computer (e.g. Raspberry Pi, Edison) / Networks & Cloud

Programming Language: Java, Python, Javascript/Programming

Sensor: DS18B20 "one wire" sensor/ Devices & Systems

Electronic Equipment: Resistors, breakout board/bread board/ Devices & Systems

Other Practical Skills/Domains: Programming(fundamentals), soldering and wiring, computer architecture, operating systems, digital electronics.

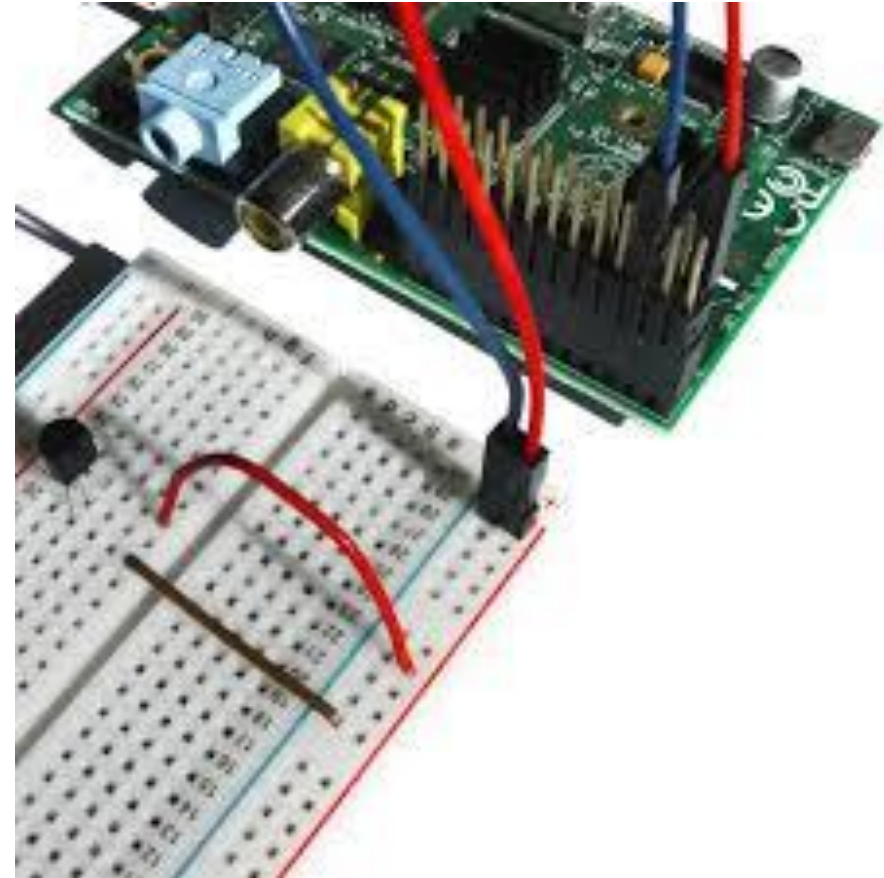

Project II - Ideas

